

Request For Quotation

Order the parts you need from our real-time inventory database. Simply complete a request for quotation form with your part information and a sales representative will respond to you with price and availability.

[Request For Quotation](#)

Your free datasheet starts on the next page.

More datasheets and data books are available from our homepage: <http://www.datasheetarchive.com>

Wireless Audio Link IC

BH1414K

The BH1414K is a FM stereo transmitter IC that uses a simple configuration. This IC consists of a stereo modulator for generating stereo composite signals and a FM transmitter for broadcasting a FM signal on the air. A high S/N ratio and good timbre transmitter circuit can be composed with a few components. It is available for many applications due to the varieties of setting such as transmission output by serial data input.

●Applications

CD changer, Car TV, Car navigation, Wireless speakers, Personal computer (sound board), Game machine

●Features

- 1) It is possible to improve the timbre because it has the pre-emphasis circuit, limiter circuit, and the 19kHz/38kHz low-pass trap filter circuit.
- 2) Built-in pilot-tone system FM stereo modulator circuit.
- 3) The transmission frequency is stable because it has a PLL system for the FM transmitter circuit.
- 4) PLL data input (CE, CK, DA) by serial input.
- 5) It is possible for input level setting, monaural operation and output ON/OFF control by serial input.
- 6) It is possible for the transmission output control.

●Absolute maximum ratings (Ta = 25°C)

Parameter	Symbol	Limits	Unit
Supply voltage	V _{CC1}	+9.0	V
	V _{CC2}	+10.0	
Power dissipation	P _d	500	mW
Storage temperature range	T _{stg}	-55 to +125	°C

* Reduced by 5mW for each increase in Ta of 1°C over 25°C.

●Recommended operating conditions (Ta = 25°C)

Parameter	Symbol	Min.	Typ.	Max.	Unit
Operating supply voltage	V _{CC}	4.5	–	5.5	V
Operating temperature range	T _{opr}	-40	–	+85	°C
Audio input level	V _{IN-A}	–	–	500	mVrms
Audio input frequency	f _{IN-A}	20	–	15k	Hz
Transmission frequency	f _{TX}	75	–	110	MHz

●Application example

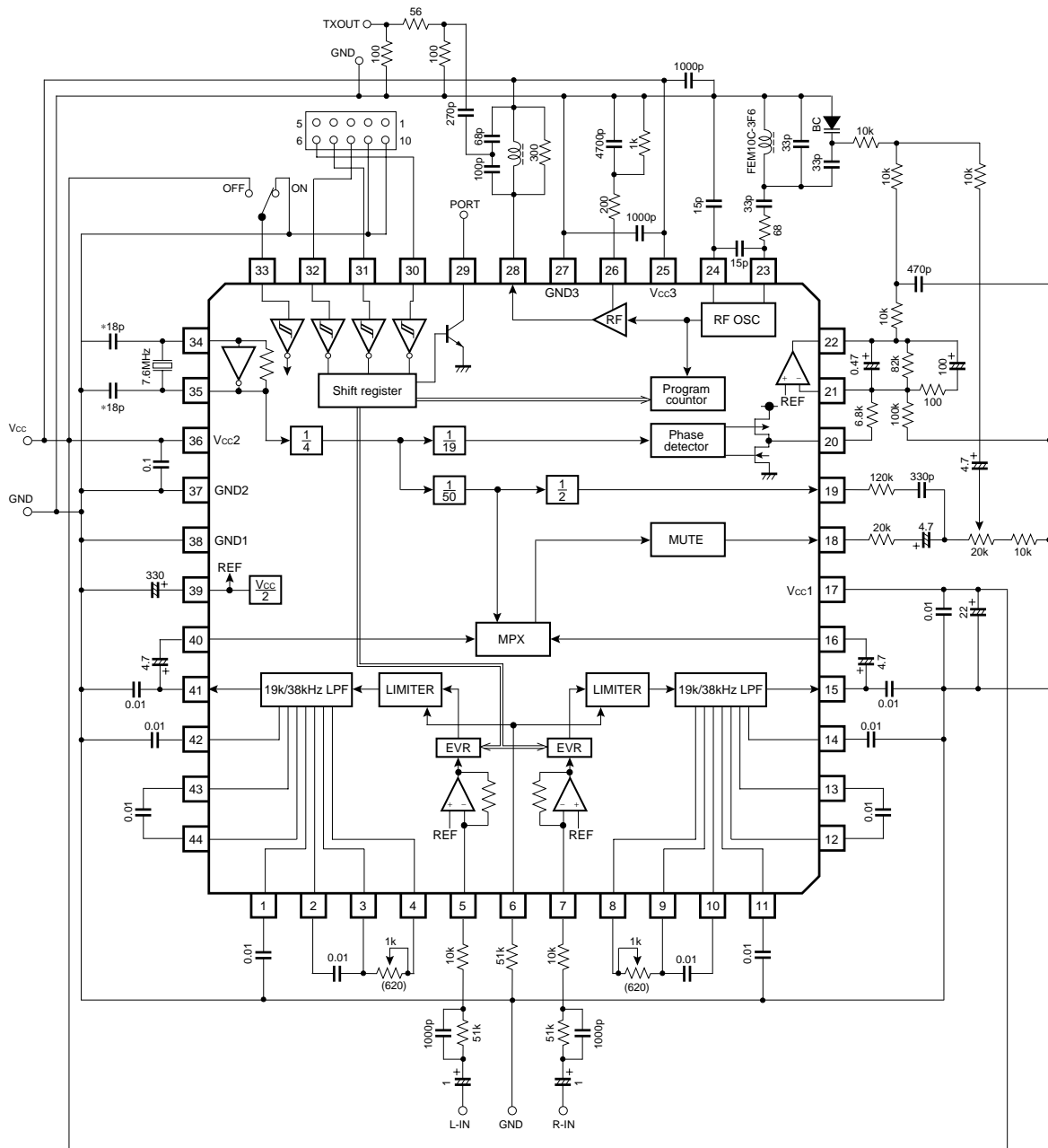

*The constant of the capacitor must be determined by the agreement with a crystal maker.

Multimedia ICs

●External dimensions (Units : mm)

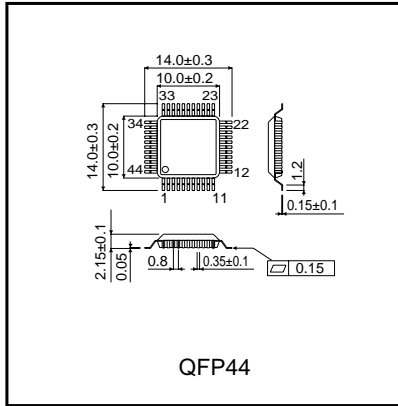

Notes

- No technical content pages of this document may be reproduced in any form or transmitted by any means without prior permission of ROHM CO.,LTD.
- The contents described herein are subject to change without notice. The specifications for the product described in this document are for reference only. Upon actual use, therefore, please request that specifications to be separately delivered.
- Application circuit diagrams and circuit constants contained herein are shown as examples of standard use and operation. Please pay careful attention to the peripheral conditions when designing circuits and deciding upon circuit constants in the set.
- Any data, including, but not limited to application circuit diagrams information, described herein are intended only as illustrations of such devices and not as the specifications for such devices. ROHM CO.,LTD. disclaims any warranty that any use of such devices shall be free from infringement of any third party's intellectual property rights or other proprietary rights, and further, assumes no liability of whatsoever nature in the event of any such infringement, or arising from or connected with or related to the use of such devices.
- Upon the sale of any such devices, other than for buyer's right to use such devices itself, resell or otherwise dispose of the same, no express or implied right or license to practice or commercially exploit any intellectual property rights or other proprietary rights owned or controlled by
- ROHM CO., LTD. is granted to any such buyer.
- Products listed in this document use silicon as a basic material.
Products listed in this document are no antiradiation design.

The products listed in this document are designed to be used with ordinary electronic equipment or devices (such as audio visual equipment, office-automation equipment, communications devices, electrical appliances and electronic toys).

Should you intend to use these products with equipment or devices which require an extremely high level of reliability and the malfunction of which would directly endanger human life (such as medical instruments, transportation equipment, aerospace machinery, nuclear-reactor controllers, fuel controllers and other safety devices), please be sure to consult with our sales representative in advance.

About Export Control Order in Japan

Products described herein are the objects of controlled goods in Annex 1 (Item 16) of Export Trade Control Order in Japan.

In case of export from Japan, please confirm if it applies to "objective" criteria or an "informed" (by MITI clause) on the basis of "catch all controls for Non-Proliferation of Weapons of Mass Destruction.